

Magnetic Tools

54000 GT Magnetic Induction Block



Features :

- ▶ Non-magnetic GT1, GT2 and GT3 can be magnetized after induced on any magnetic chuck applying for as plate or 45° fixture.
- ▶ It is used as auxiliary tool by applying with magnetic chuck for holding round, thin or shapes that difficult to hold.
- ▶ There are mainly two types of induction blocks, rectangle and M shape for different processing demands.

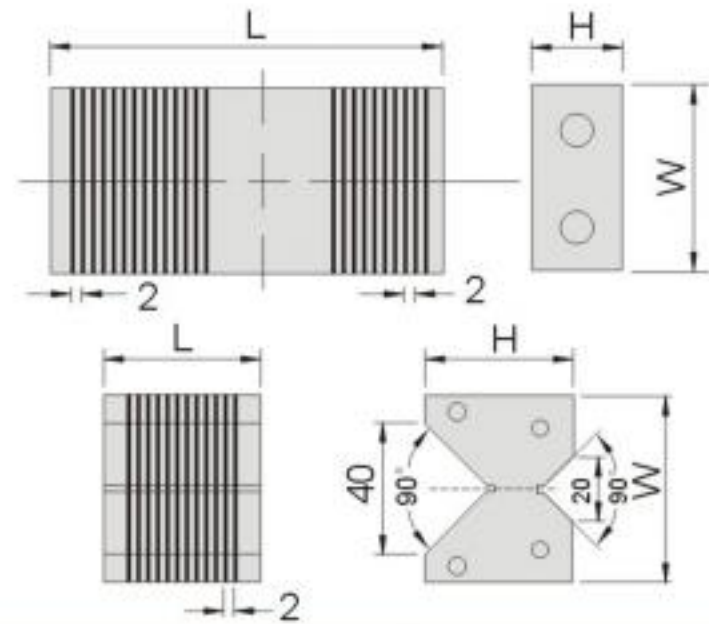

Unit:mm

Order No.	Model	L	W	H	Qty	N.W.
54000-10	GT1	100	50	25	2	2kg
54000-20	GT2	49	58	46	2	1.7kg
54000-30	GT3	100	58	46	1	3.4kg

54010 AT Magnetic Induction Block (Aluminium made)

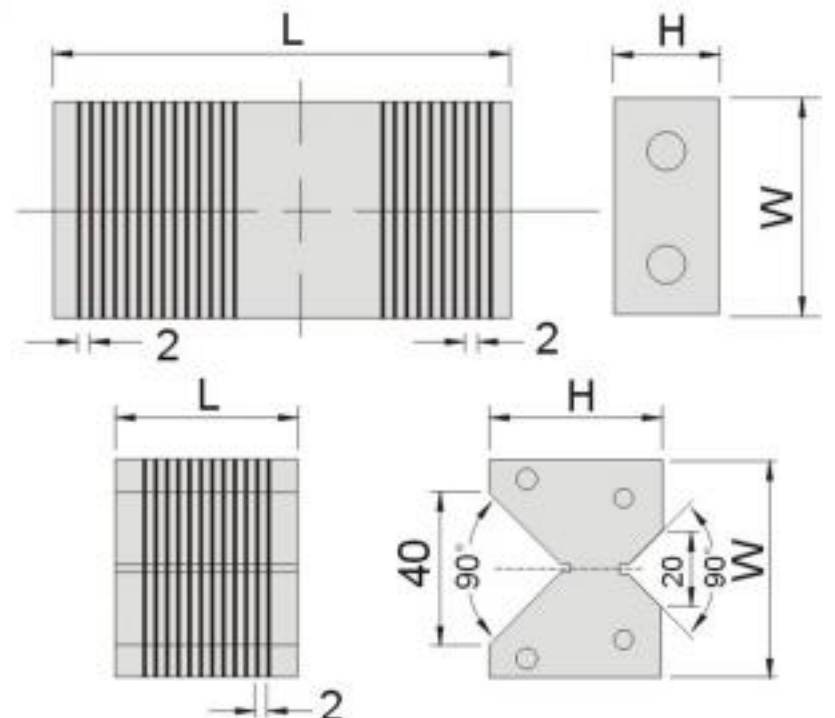

Unit:mm

Order No.	Model	L	W	H	Qty	N.W.
54010-10	AT1	100	50	25	2	1.2kg
54010-20	AT2	49	58	46	2	1.2kg
54010-30	AT3	100	58	46	1	1.2kg

MAGNETIC TOOLS

54020 HT Magnetic Induction Block

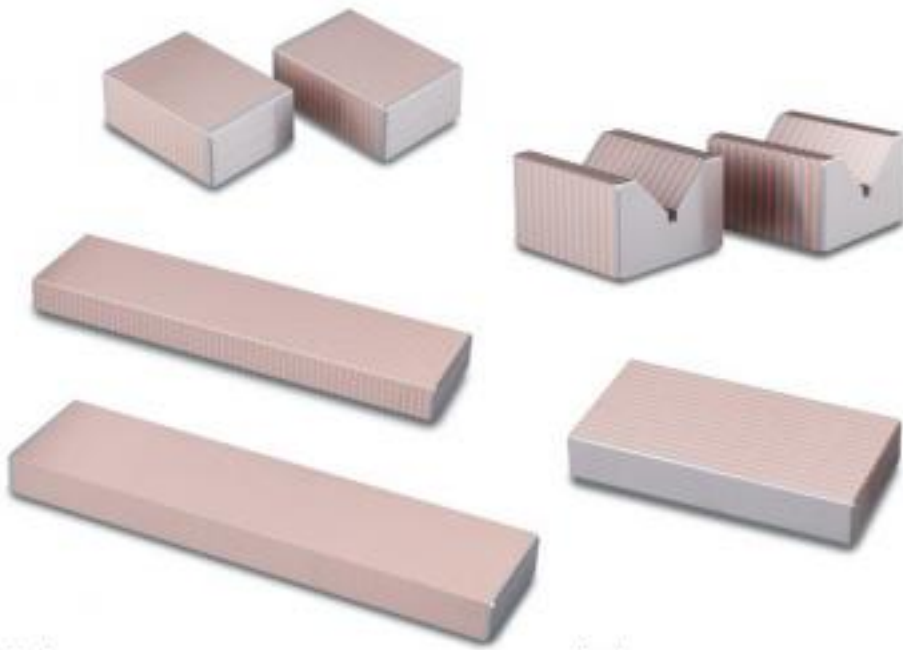

Features :

- ▶ Made of iron and copper with brazing welding fixed, can cut in any shapes and will not deform easily.
- ▶ It will be magnetized after inducted on any magnetic chuck applying for as plate or 45° fixture and used as auxiliary tool for holding round, thin or shapes that difficult to hold.
- ▶ There magnetic block itself is not magnetic, and it can be magnetic by placed on a magnetic chuck, which can then be used for effective processing.
- ▶ 20% magnetic force reduced when thickness over 25mm.

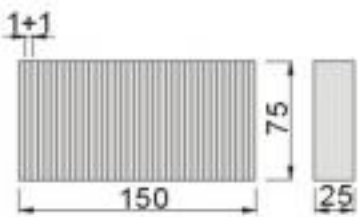

54020-01 HTW-150

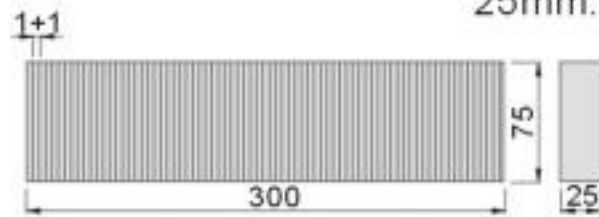

54020-02 HTW-300

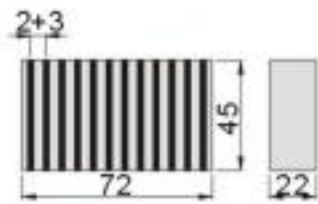

54020-03 HT-75

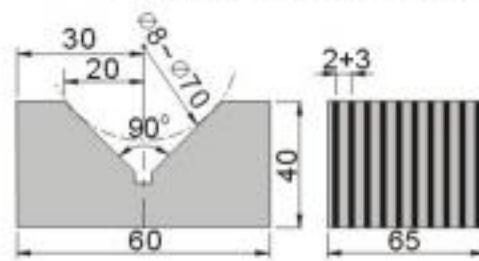

54020-04 HTV-60

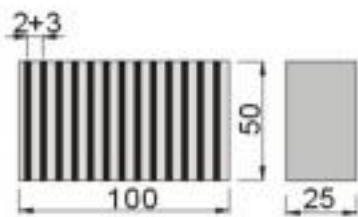

54020-05 HT-100

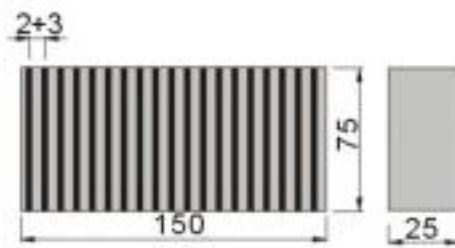

54020-06 HT-150

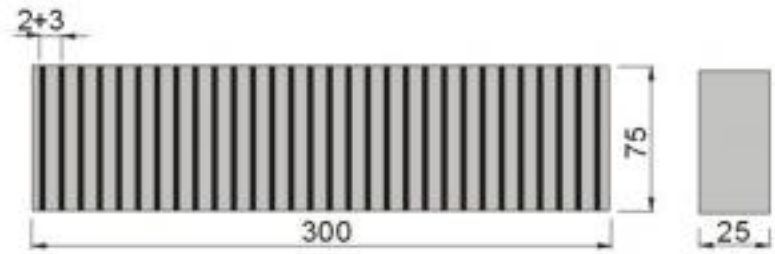

54020-07 HT-300

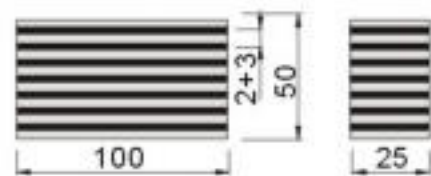

54020-08 HTL-100

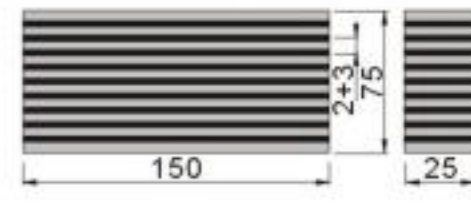

54020-09 HTL-150

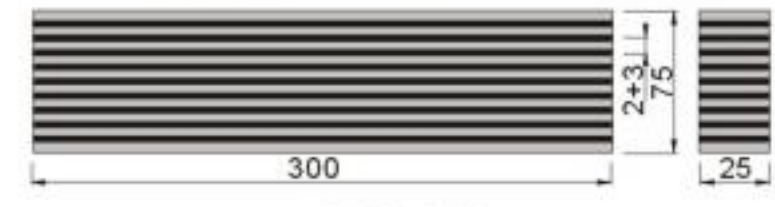

54020-10 HTL-300

Unit:mm

Order No.	Model	L	W	H	Pole pitch	Qty	N.W.
54020-01	HTW-150	150	75	25	2(1+1)	1 PCS	2.2kg
54020-02	HTW-300	300	75	25	2(1+1)	1 PCS	4.4kg
54020-03	HT-75	72	45	22	5(2+3)	2 PCS	1.2kg
54020-04	HTV-60	65	60	40	5(2+3)	2 PCS	2.5kg
54020-05	HT-100	100	50	25	5(2+3)	2 PCS	2.0kg
54020-06	HT-150	150	75	25	5(2+3)	1 PCS	2.2kg
54020-07	HT-300	300	75	25	5(2+3)	1 PCS	4.4kg
54020-08	HTL-100	100	50	25	5(2+3)	2 PCS	2.0kg
54020-09	HTL-150	150	75	25	5(2+3)	1 PCS	2.2kg
54020-10	HTL-300	300	75	25	5(2+3)	1 PCS	4.4kg

Magnetic Tools

54030 GVH Magnetic V-block

GVH2



GVH1



GVH3

Features :

- ▶ Suitable for applying as a plate or 45° fixture and used as auxiliary tool for holding round, thin or shapes that difficult to hold.
- ▶ Light grinding, milling, tapping, drilling is applicable.
- ▶ Strong mag. force on top, bottom and V groove.
- ▶ Suitable for applying two types accuracy job, standard or special.
- ▶ On/Off switch, easy for operation and portable.

MAGNETIC TOOLS

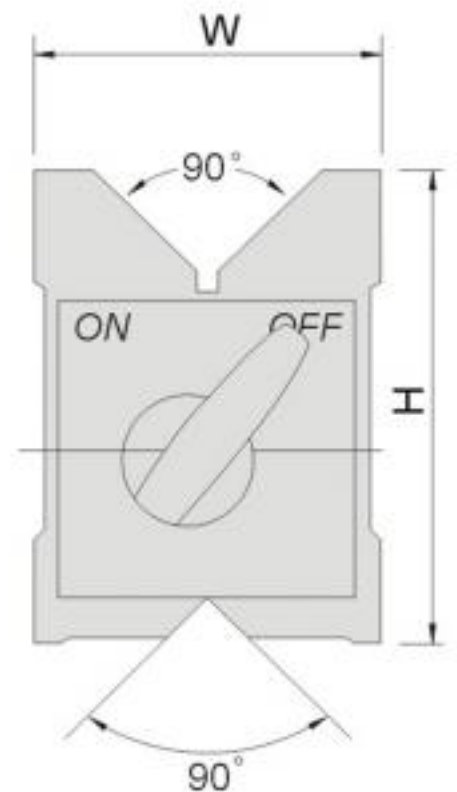
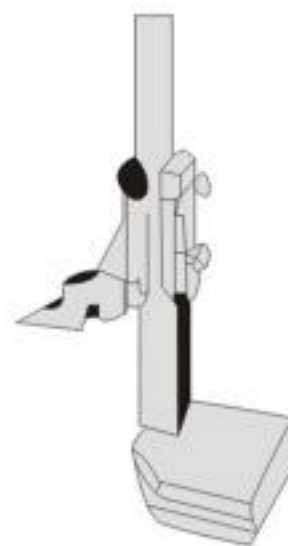
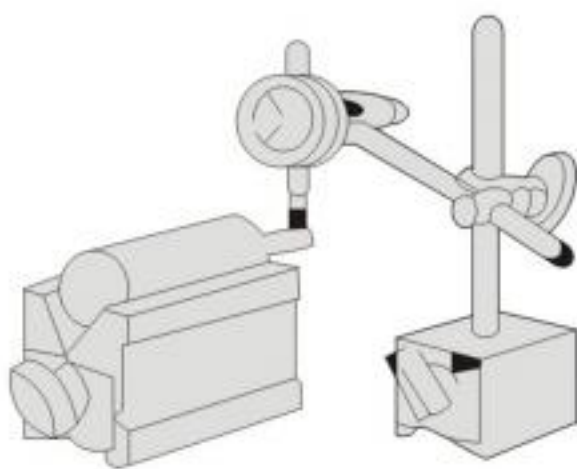

Unit:mm

Order No.	Model	Mag. Force		Specification			N.W.
		Round	Flat	L	W	H	
54030-10	GVH1	55kgf	70kgf	80	56	72	1.8kg
54030-20	GVH2	90kgf	110kgf	115	76	100	5.1kg
54030-30	GVH3	55kgf	70kgf	120	61	73	3.1kg

54040
GVH
Magnetic V-block
GVH30

GVH40

GVH60

Features :

- ▶ GVH30/40/60 are suitable for applying long or round workpiece.
- ▶ Suitable for holding round or rectangle shape steel for precision measuring, marking and grinding.
- ▶ Two pieces in a set with uniform spec. for standard and accuracy.
- ▶ On/Off switch, easy for operation and portable.
- ▶ Sold in a pair.

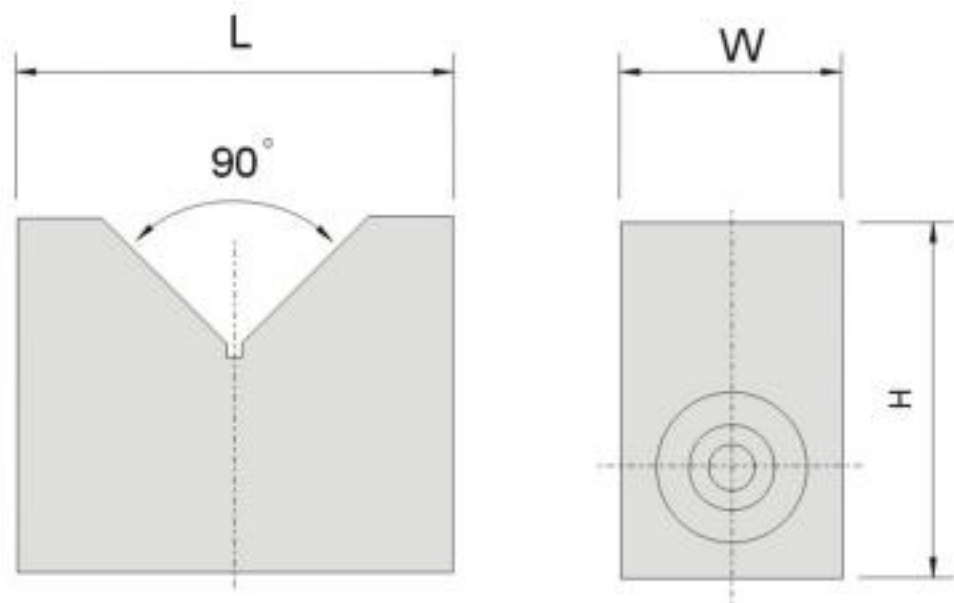

Unit:mm

Order No.	Model	Mag. Force	Capacity	Specification			N.W.
				L	W	H	
54040-30	GVH30	15kgf	∅50	70	40	50	2kg
54040-40	GVH40	20kgf	∅80	100	50	80	6kg
54040-60	GVH60	23kgf	∅125	150	50	100	10kg

Magnetic Tools

54050

BA

Magnetic Square Block



Features :

- ▶ Suitable for holding round or rectangle shape steel for precision measuring and marking.
- ▶ Magnetic suction is available on both sides, top face & v-face.
- ▶ V-face is provided at 2 sections each at right angle for easy application.
- ▶ Precisely ground and inspected.

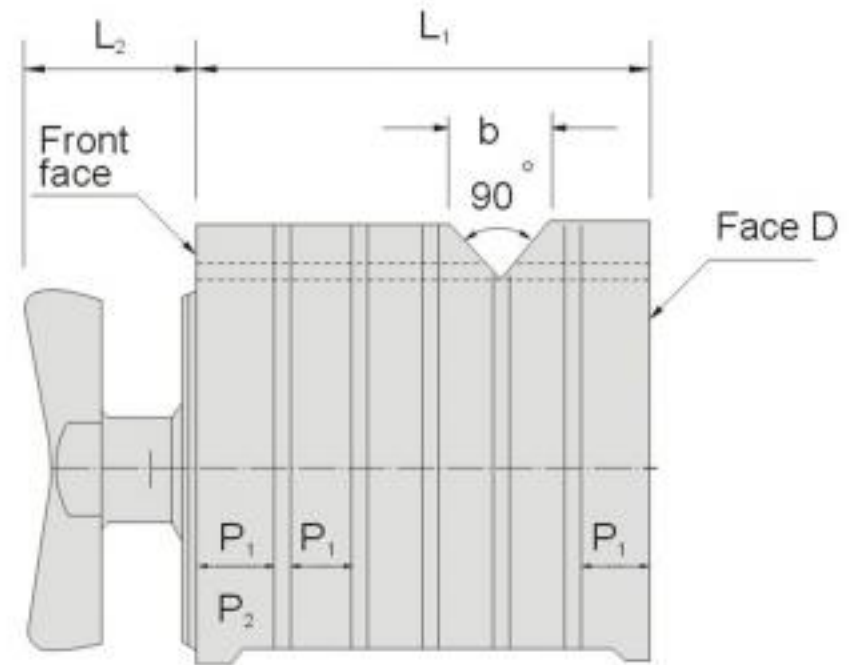
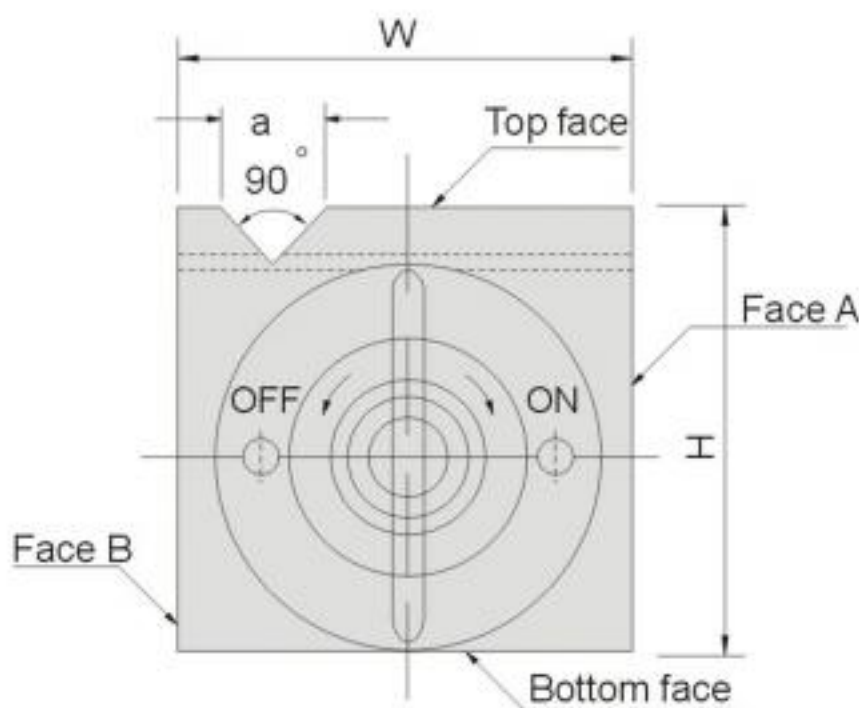
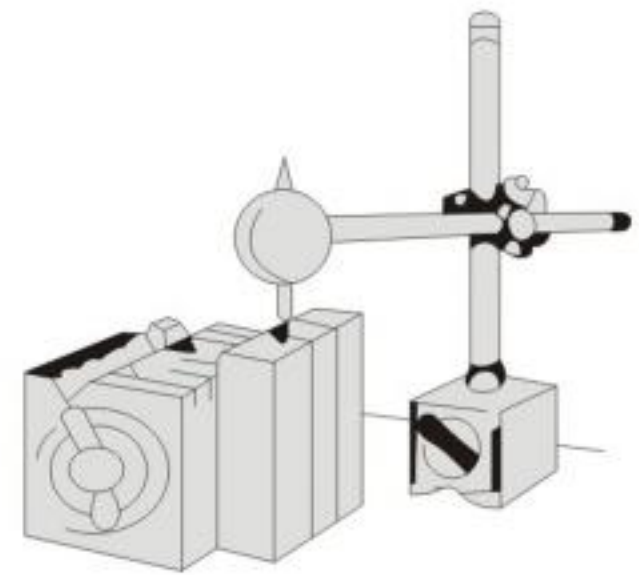

Unit:mm

Order No.	Model	V-Face Holding Power		Flat-Face Holding Power	
		Steel	Cast iron	Steel	Cast iron
54050-10	BA1	30kgf	25kgf	50kgf	30kgf
54050-20	BA2	60kgf	35kgf	180kgf	100kgf

Order No.	Model	Specification								N.W.
		W	L1	H	L2	P1	P2	P3	a/b	
54050-10	BA1	100	100	100	43	17	4	12	26	6.3kg
54050-20	BA2	150	150	150	56	24.5	5	19	32	21.3kg

54058
DSM
Double-Sided Permanent Magnetic Chuck

Features :

- ▶ Suitable for surface grinder, EDM & for inspection purpose.
- ▶ Lightweight & operation simple.
- ▶ Good in waterproof.
- ▶ Other lateral faces also have magnetic.

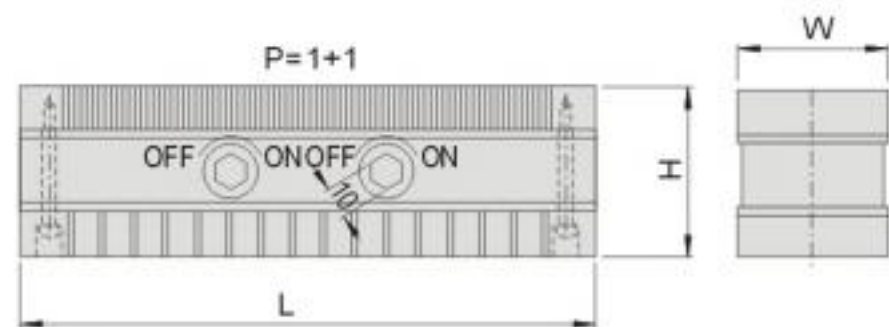

Unit:mm

Order No.	Model	Spec.	Specification			Pole Pitch	N.W.
			L	W	H		
54058-01	DSM-15	50x150	150	50	58	2(1+1)	3.5kg
54058-02	DSM-20	50x200	200				4.7kg
54058-03	DSM-25	50x250	250				5.9kg

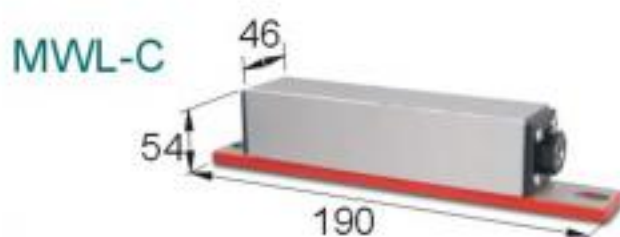
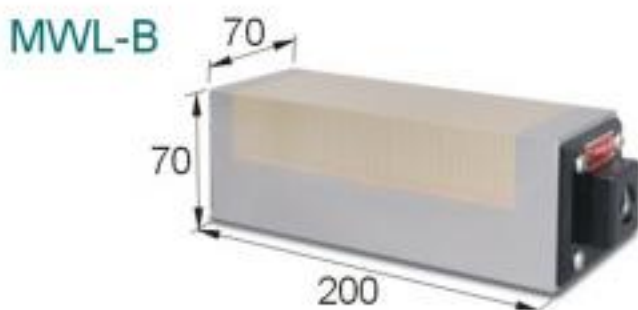
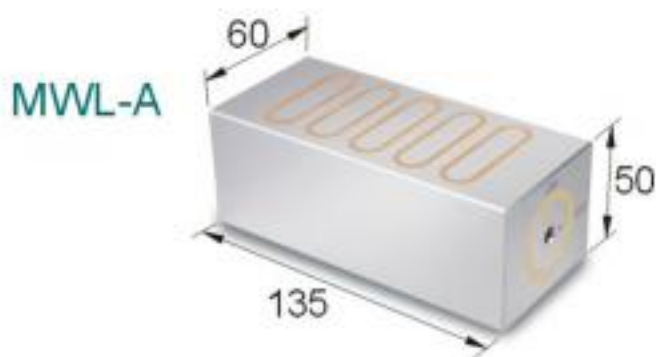
54060
MWL
Permanent Magnetic Chuck

(Wire cutting machine applicable)

Features :

- ▶ Suitable for applying in grinding, milling, EDM, Wire Cutting and measuring machines.
- ▶ Attractions are available on several faces and capable of holding small and thing workpieces. Attraction can be adjustable and prevent distortion.
- ▶ Suitable for processing 90° fixture.
- ▶ Applying two magnetic chucks for shifting processing, easier and efficient.
- ▶ Easily to disassemble workpieces when OFF, no magnetic force remained.

Unit:mm

Order No.	Model	Pole Pitch	N.W.
54060-01	MWL-A	10(2+6+2)	3.5kg
54060-02	MWL-B	2(0.5+1.5)	7.5kg
54060-03	MWL-C	2(1+1)	3.7kg

Magnetic Chuck

54065 MWT Stainless Steel Square Permanent Magnetic Chuck



Example:



Features :

- ▶ As example shown, the ground work-piece is taken to a datum surface on the datum side of the magnetic chuck, and then the uppermost surface is ground to obtain both sides for precision squareness surfaces.
- ▶ Bottom plate is made of SUS420 for rusty resistance and the top plate is made of SUS304 & SS400 with heat treatment and maintenance shall be carried out for SS400 after use. Applying ceramic-like magnet with good wear-resistance.
- ▶ Squareness with datum and each sides is within 0.003mm.

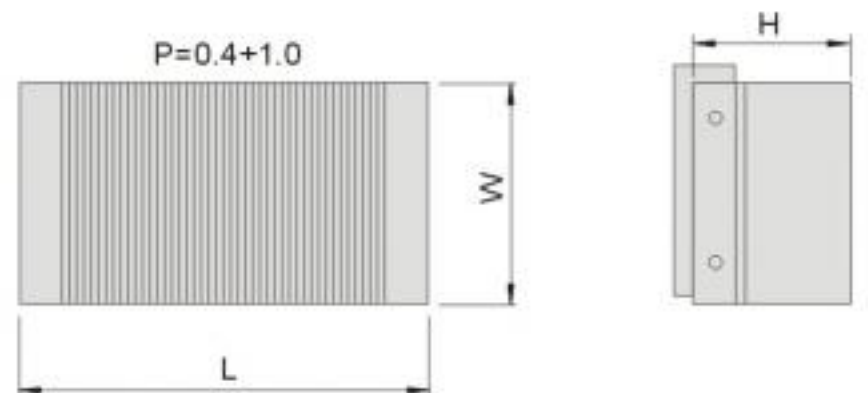

Unit:mm

Order No.	Model	W	L	H	Pole Pitch	N.W.
54065-01	MWT0813	80	130	60	1.4 (0.4+1.0)	7.0kg
54065-02	MWT1020	100	200	60		10.0kg
54065-03	MWT1515	150	150	80		25.0kg

54070
MWS
Permanent Magnetic Chuck (Vertical Type)

Features :

- ▶ Suitable for applying workpiece inspection of vertical auxiliary by using its magnetic force to achieve stability.
- ▶ Sub-zero treatment and HRC56° ensure its accuracy, material SKD11 is applied for its base.
- ▶ Squareness and parallelism are within $\pm 0.002\text{mm}$.

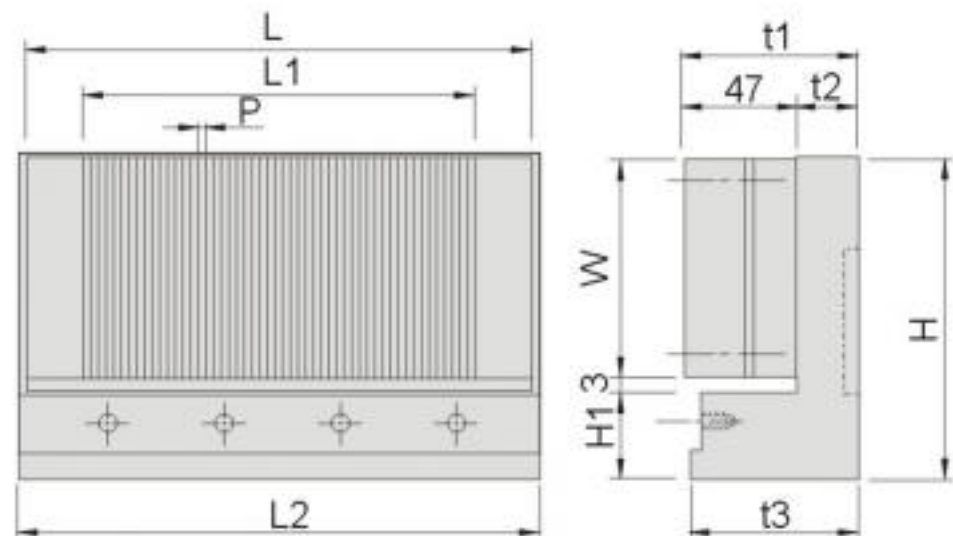

Unit:mm

Order No.	Model	W	L	L1	P	L2	t3	t1	t2	H	H1	N.W.
54070-10	MW307S	75	175	130	1+1	180	65	67	20	111	30	9.7kg
54070-20	MW407S	100	175	130	1+1	180	65	67	20	136	30	13kg
54070-30	MW510S	125	250	205	1+1	255	65	67	20	161	30	23kg